



# EZ OIL™ FRESH OIL DISPENSING SYSTEM

The OilCare® EZ Oil™ Fresh Oil Dispensing System is an automated, convenient, safer and more cost-effective way to refill fryers with fresh cooking oil. Simply place boxes or jugs upside-down in OilCare® racks and fill your fryers. The system is directly plumbed to the fryer for a fully automated solution. Upside-down storage dispenses every drop of oil, increasing yields by up to 5%.

## CONSTRUCTION AND FEATURES

- Heavy-gauge stainless steel construction
- Freestanding
- Standard shortening capacity: 350 Lb/42 Gal (158 kg/158.987 l)
- For multiple fryers or multiple kitchens, standard three jib dispensing configuration can be upgraded to link multiple jib racks, increasing fill capacity
- Control panel with alarm
- UL, UL Sanitation Listed (U.S. and Canada)
- Suitable for automatic top-off systems
- Easy to access and service components
- One-year warranty on all parts and components
- Worldwide delivery and installation available

## BENEFITS

- Minimal handling of fresh cooking oil
- Insurance and Workers' Comp savings
- Less employee downtime
- Labor savings and greater employee safety
- Great option to bulk delivery of cooking oil
- Avoid pollution fines

## Installation and Operating Specifications

Model	RACK3-NA RACK SYSTEM
Power Requirements	110 V 15 A - 250 V 3.5 A, 50/60 Hz
Installation Space Requirements	18 in. l x 38 in. w x 54 in. h (458 mm x 966 mm x 1372 mm)
Shortening Capacity	350 Lb/42 Gal (158 kg/158.987 l)
Shipping Weight	70 lb (32 kg)
Documentation	Installation guide, Operating guide
Warranty	One-year parts and labor



# EZ OIL™ FRESH OIL DISPENSING SYSTEM

MODEL RACK3-NA

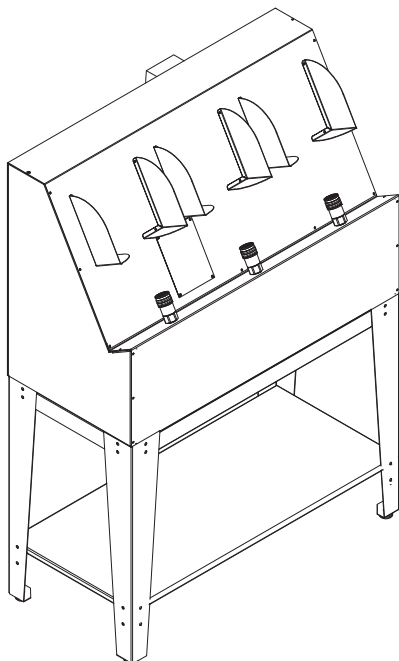
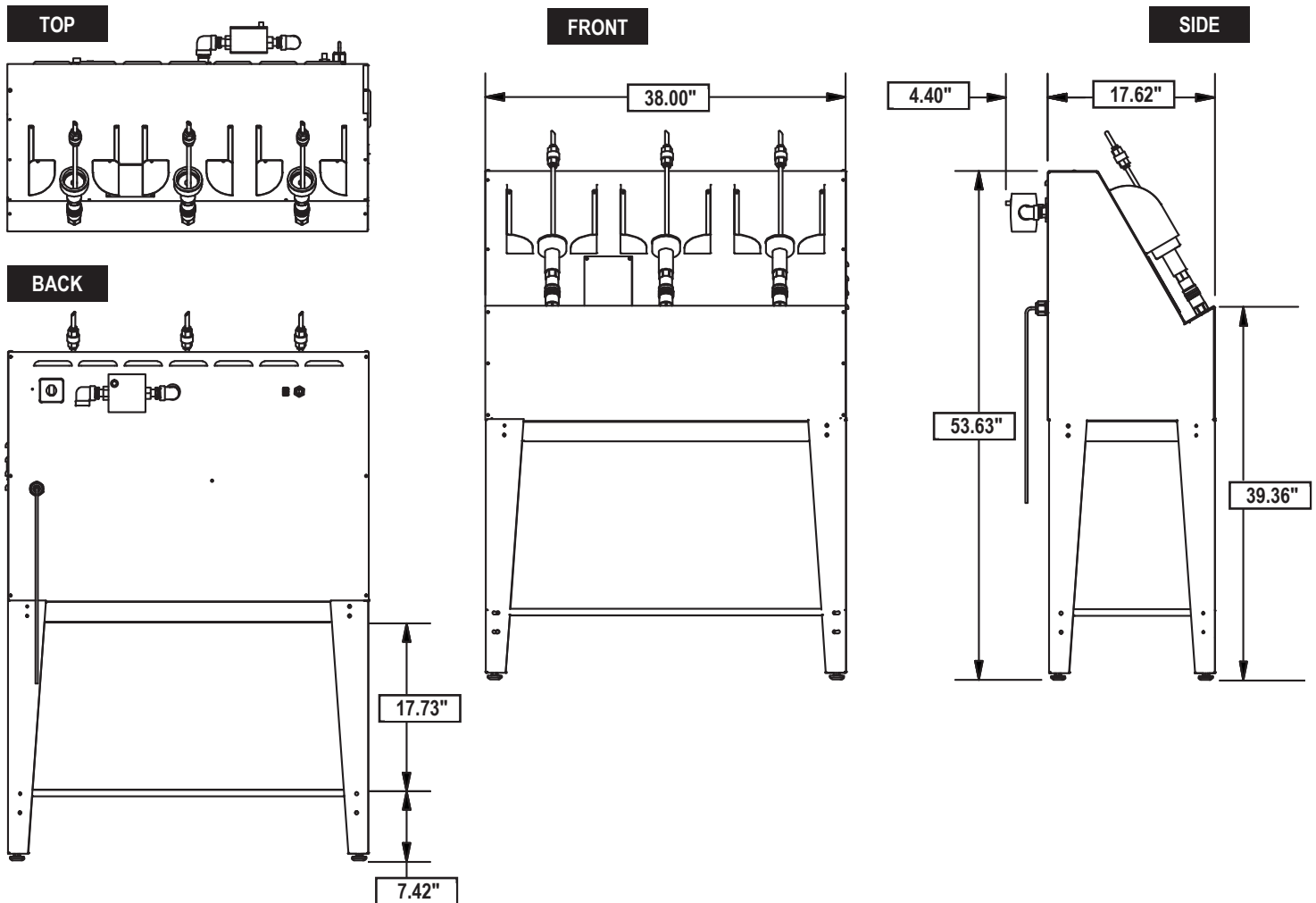

## IMPORTANT

- The appliance is not to be used by persons (including children) with reduced physical, sensory or mental capabilities, or lack of experience and knowledge, unless they have been given supervision or instruction.
- Children should be supervised to ensure that they do not play with the appliance.
- If the supply cord is damaged, it must be replaced by the manufacturer, its service agent or similarly qualified persons in order to avoid a hazard.
- Not intended to be operated by means of an external timer or a separate remote-control system.
- This appliance is intended to be used in Commercial kitchen applications
- Regarding OilCare® Fresh Oil Pump Station (FOPS): the maximum total head available is 5m.

### OilCare®, Inc., Inc.

187 Ascot Parkway • Cuyahoga Falls, Ohio 44223  
330-861-1100 • 877-776-1100 • oilcareii.com  
Fax: 330-861-1105 • info@oilcareii.com

