



# WASTE COOKING OIL CONTAINMENT TANK

MODEL 2478SQ-NA

## CONSTRUCTION AND FEATURES

- Heavy-gauge stainless steel exterior (sides, bottom and legs)
- Freestanding, 24 in. (609 mm) square x 85.5 in. (1981 mm) height
- Stainless steel tank bottom and legs
- 6 in. (152 mm) high stainless steel legs and floor clearance
- Tank capacity 1100 Lb/150 Gal (499 kg/567.8 l)
- Control panel with power indication or digital reader
- Level indicators with safety overflow protection
- UL, UL Sanitation Listed (U.S. and Canada)
- Suitable for Direct-Plumbed®, Remote-Plumbed® or Caddy systems
- Easy to access and service components
- One-year warranty on all parts and components
- Worldwide delivery and installation available

## BENEFITS

- Minimal or no handling of hot waste shortening
- Insurance and Workers' Comp savings
- Less employee downtime
- Labor savings and greater employee safety
- Cleaner grounds and image
- Waste oil of higher value to collection companies
- Avoid pollution fines

## Installation and Operating Specifications

Model	2478SQ-NA Containment Tank
Power Requirements	110 V 15 A - 250 V 3.5 A, 50/60 Hz
Installation Space Requirements	24.25 in. l x 24.25 in. w x 85.5 in. h (615mm x 615mm x 2172mm)
Shortening Capacity	1100 Lb/150 Gal (499 kg/567.8 l)
Shipping Weight	250 lb (114 kg)
Documentation	Installation guide, Operating guide
Warranty	One-year parts and labor



### OilCare®, Inc.

187 Ascot Parkway • Cuyahoga Falls, Ohio 44223  
330-861-1100 • 877-776-1100 • oilcareii.com  
Fax: 330-861-1105 • info@oilcareii.com



© OilCare®, 10/16

# WASTE COOKING OIL CONTAINMENT TANK

MODEL 2478SQ-NA

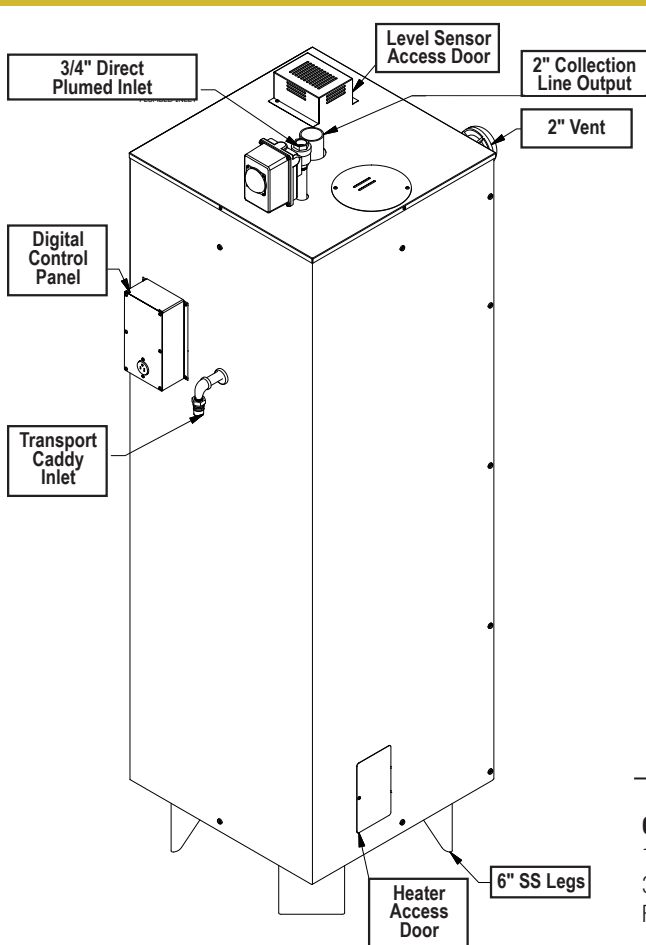
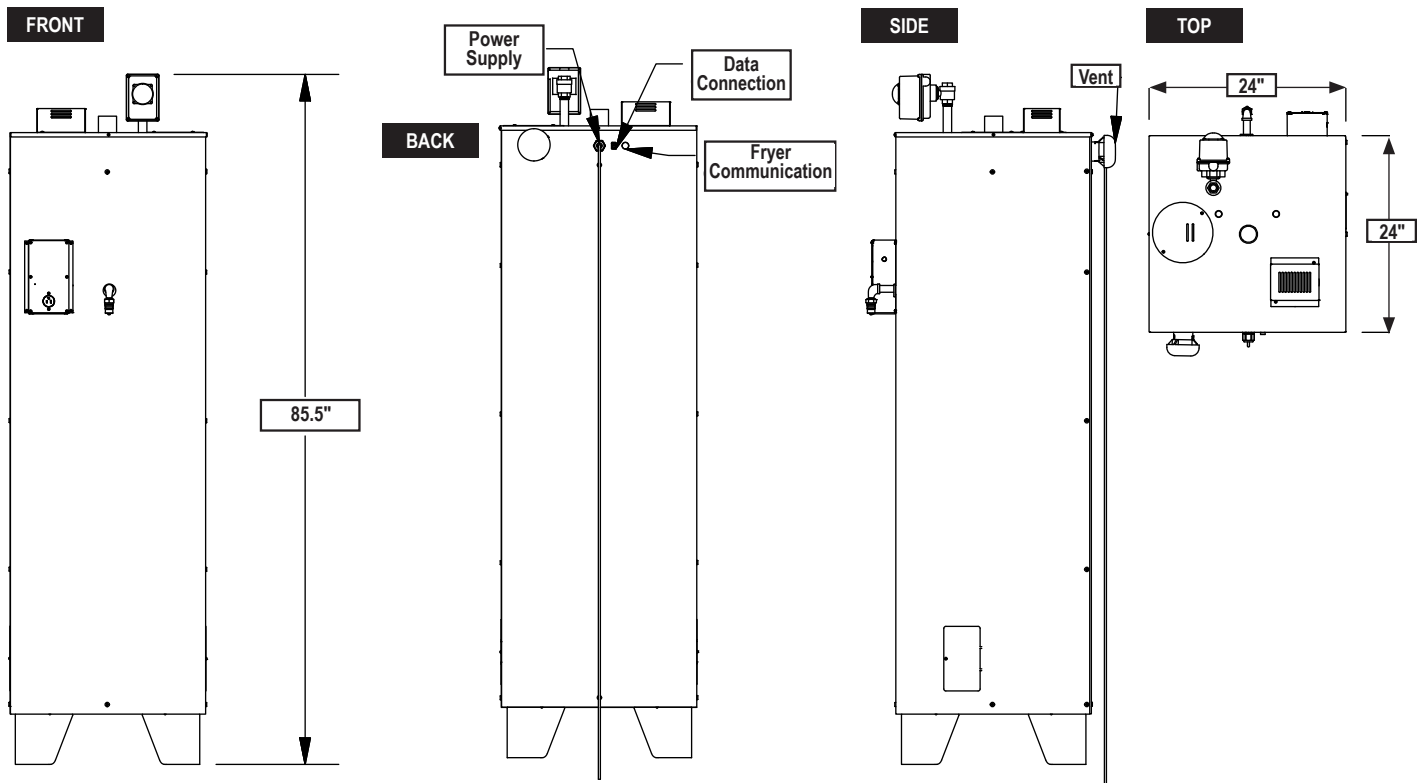

## IMPORTANT

- The appliance is not to be used by persons (including children) with reduced physical, sensory or mental capabilities, or lack of experience and knowledge, unless they have been given supervision or instruction.
- Children should be supervised to ensure that they do not play with the appliance.
- If the supply cord is damaged, it must be replaced by the manufacturer, its service agent or similarly qualified persons in order to avoid a hazard.
- Not intended to be operated by means of an external timer or a separate remote-control system.
- This appliance is intended to be used in commercial kitchen applications.

### OilCare®, Inc.I, Inc.

187 Ascot Parkway • Cuyahoga Falls, Ohio 44223  
 330-861-1100 • 877-776-1100 • oilcareii.com  
 Fax: 330-861-1105 • info@oilcareii.com





# TRANSPORT CADDY

MODEL 10SS-NA

75 LB. / 10 GAL. SHORTENING CAPACITY

OilCare® stainless steel transport caddies are the most economical method of transporting grill grease and cooking oil to the containment tank.

## HOW IT WORKS

Drain used grease into caddy. System includes extra-large grill sediment basket. Close the caddy lid, secure the lid with the safety latch, and carefully pull the cart slowly to the used oil storage tank or pumping station. Connect the hose from the grease caddy to a OilCare® storage tank fill station and simply pump used grease into the containment tank.

## CONSTRUCTION AND FEATURES

- Holds 75 lb (10 gal) (34 kg/37.8 l)
- 100% heavy stainless steel construction
- Smooth rolling heavy-duty, non-mark casters
- Swivel front casters with brakes
- Extra-large “crumb catcher” basket
- Power switch and “break away” power cord
- Removable handle
- Lock-in-place safety cover
- Easy, quick-disconnect fittings
- High-temperature hose
- 110 V 15 A - 250 V 3.5 A industrial 1/2HP motor
- Specially designed 5-gallon (19 l) per minute pump
- Roller pump will not “shear” oil during filtration
- Special filter screen to protect pump
- Easy-to-clean, seamless construction
- UL, UL Sanitation Listed
- One-year warranty on all components



*OilCare®'s Shortening Filtration Upgrade Kit allows for any Waste Shortening Transport Caddy to become a state-of-the-art, heavy-duty oil filtration machine.*

## Installation and Operating Specifications

Model	10SS-NA
Size	32 in. l, 12 in. w, 9.5 in. h (812 mm x 305 mm x 241.3 mm)
Power	110 V 15 A - 250 V 3.5 A, 50/60 Hz
Capacity	75 lb /10 gal (34 kg/37.8 l)
Ship Wt.	125 lbs (56.7 kg)

## Popular Caddy Options

10SS-NA-LP	Low Profile Transport Caddy	75 Lb/10 Gal (34 kg/37.8 l)
16SS-NA-W5	Transport Caddy with 5" (12.7cm) Casters	120 Lb/16 Gal (54.4 kg/60.5 l)
20SS-NA-W5	Transport Caddy with 5" (12.7cm) Casters	150 Lb/20 Gal (68 kg/75.7 l)

## Filter Upgrade Kits

FILTER-KIT-FP	Caddy-To-Filtration System Upgrade Kit, Paper Media Filter	Not applicable
FILTER-KIT-FC16	Caddy-To-Filtration System Upgrade Kit, Carbon Media Filter	Not applicable
FILTER-KIT-FS	Caddy-To-Filtration System Upgrade Kit, Stainless Steel Media Filter	Not applicable

# WASTE COOKING OIL CONTAINMENT CADDY

MODEL 10SS-NA

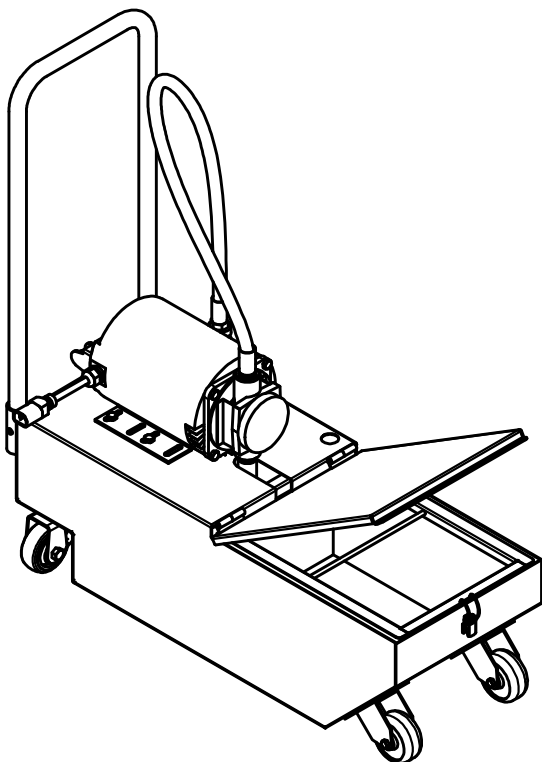
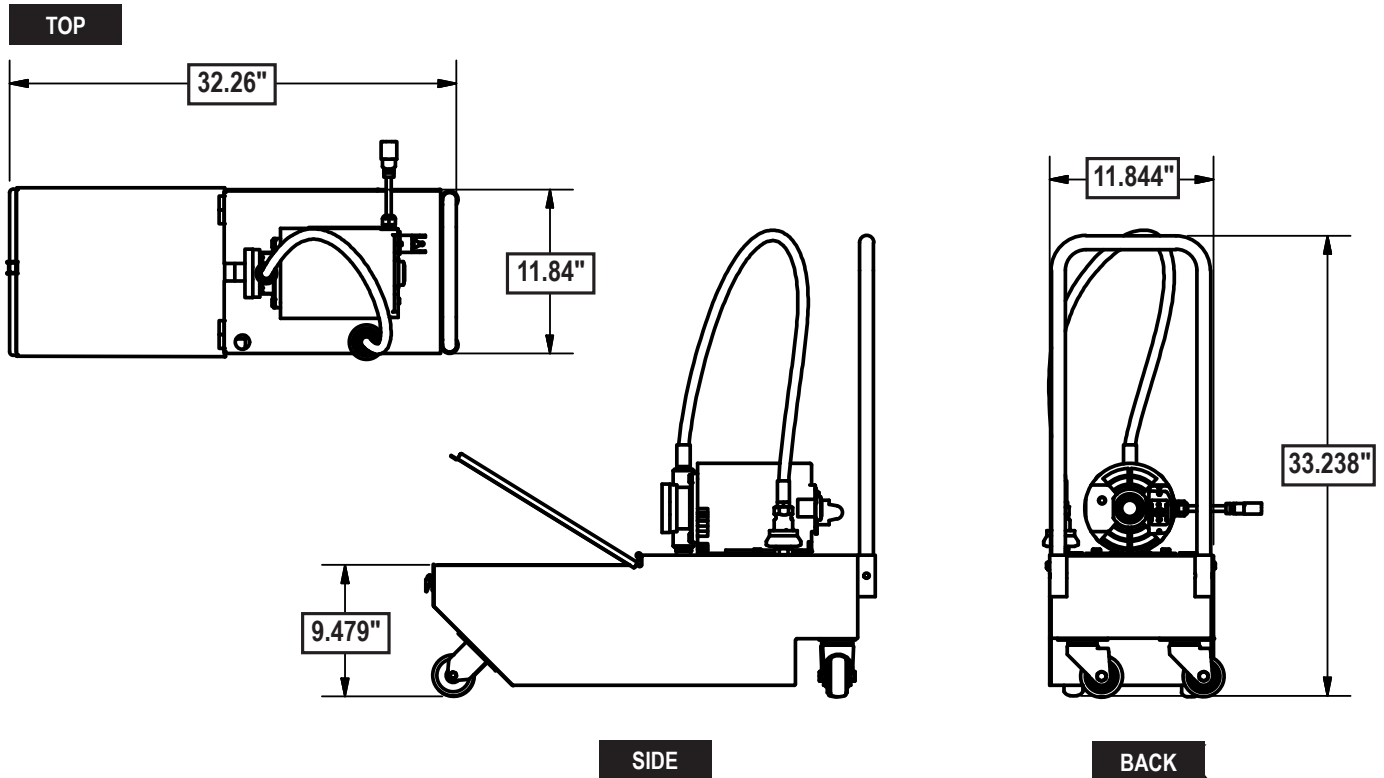

## IMPORTANT

- The appliance is not to be used by persons (including children) with reduced physical, sensory or mental capabilities, or lack of experience and knowledge, unless they have been given supervision or instruction.
- Children should be supervised to ensure that they do not play with the appliance.
- If the supply cord is damaged, it must be replaced by the manufacturer, its service agent or similarly qualified persons in order to avoid a hazard.
- Not intended to be operated by means of an external timer or a separate remote-control system.
- This appliance is intended to be used in commercial kitchen applications.

## Frontline International, Inc.

187 Ascot Parkway • Cuyahoga Falls, Ohio 44223  
330-861-1100 • 877-776-1100 • frontlineii.com  
Fax: 330-861-1105 • info@frontlineii.com

